

**DEMMERI®**



ITALIAN DESIGN



## OEMMEBI MACHINES

Hello,

Welcome to the world of OEMMEBI!

OEMMEBI is an Italian brand specializing in the production of fitness equipment and accessories for gyms and fitness clubs. Our history dates back to the 1980s, and since then, we have been emphasizing the principle of "less is more." For us, this means that functionality goes hand in hand with simple form and minimalist design.

In our products, we prioritize the highest quality materials, ensuring not only efficiency in use but also an extended product lifespan. Our professionalism is evident at every stage of production – from the initial phase of creating machines to their delivery to the customer.

OEMMEBI proudly embraces Italian design traditions, meeting user expectations for 40 years. Our clean Italian design, professional production, and special attention to our customers make us a reliable partner in the fitness market.



# CONTENTS

PLATE LOADED

4 - 23

SELECTORIZED

24 - 31

MULTISTATIONS

32 - 39

BENCHES AND RACKS

40 - 51



## PLATE LOADED

### **Precision Performance**

Plate-loaded machines are fitness equipment designed for strength training, utilizing individual weight plates for resistance. These machines provide a versatile and customizable workout experience, allowing users to adjust the load according to their fitness levels and specific training goals.

## CHEST PRESS

IRSH1707



### DIMENSIONS

L 137/W 162/H 174 cm



### MACHINE WEIGHT

153 kg



### MAX LOADING WEIGHT

200 kg



## INCLINE CHEST PRESS

IRSH1701



### DIMENSIONS

L 125/W 168/H 170 cm



### MACHINE WEIGHT

153 kg



### MAX LOADING WEIGHT

200 kg



## WIDE CHEST PRESS

IRSH1708



### DIMENSIONS

L 143/W 154/H 176 cm



### MACHINE WEIGHT

200 kg



### MAX LOADING WEIGHT

200 kg



## VERTICAL CHEST PRESS

IRSH5002



### DIMENSIONS

L 228/W 161/H 240 cm



### MACHINE WEIGHT

256 kg





## SUPINE BENCH PRESS

IRSH1722



### DIMENSIONS

L 155/W 147/H 128 cm



### MACHINE WEIGHT

78 kg



### MAX LOADING WEIGHT

200 kg



## LOW ROW

IRSH1702



### DIMENSIONS

L 139/W 128/H 165 cm



### MACHINE WEIGHT

146 kg



### MAX LOADING WEIGHT

200 kg



## PULL DOWN

IRSH1703



### DIMENSIONS

L 182/W 131/H 199 cm



### MACHINE WEIGHT

141 kg



### MAX LOADING WEIGHT

200 kg



## ROW

IRSH1709



### DIMENSIONS

L 150/W 142/H 134 cm



### MACHINE WEIGHT

152 kg



### MAX LOADING WEIGHT

200 kg



## LAT PULLDOWN

IRSH1721



### DIMENSIONS

L 127,5/W 126,5/H 199,5 cm



### MACHINE WEIGHT

170 kg



### MAX LOADING WEIGHT

150 kg



## LAT PULLDOWN

IRSH5011



### DIMENSIONS

L 217/W 174/H 203 cm



### MACHINE WEIGHT

277 kg



### MAX LOADING WEIGHT

200 kg



## SHOULDER PRESS

IRSH1704



### DIMENSIONS

L 117/W 135/H 154 cm



### MACHINE WEIGHT

140 kg



### MAX LOADING WEIGHT

200 kg



## SHOULDER LATERAL RAISE

IRSH1720



### DIMENSIONS

L 155/W 147/H 128 cm



### MACHINE WEIGHT

78 kg



### MAX LOADING WEIGHT

200 kg



## BICEPS

IRSH1713



### DIMENSIONS

L 115/W 136/H 102 cm



### MACHINE WEIGHT

118 kg



### MAX LOADING WEIGHT

100 kg



## SEATED DIP

IRSH1712



### DIMENSIONS

L 167/W 161/H 100 cm



### MACHINE WEIGHT

137 kg



### MAX LOADING WEIGHT

200 kg



## INCLINE LEG PRESS

IRSH1705



### DIMENSIONS

L 210/W 160/H 156 cm



### MACHINE WEIGHT

194 kg



### MAX LOADING WEIGHT

400 kg



## CALF PRESS

IRSH1706



### DIMENSIONS

L 186/W 106/H 119 cm



### MACHINE WEIGHT

134 kg



### MAX LOADING WEIGHT

200 kg





## LEG EXTENSION

IRSH1711



### DIMENSIONS

L 126/W 137/H 124 cm



### MACHINE WEIGHT

90 kg



### MAX LOADING WEIGHT

100 kg



## KNEELING LEG CURL

IRSH1714



### DIMENSIONS

L 109/W 165/H 140 cm



### MACHINE WEIGHT

125 kg



### MAX LOADING WEIGHT

200 kg



## HUCK SQUAT

IRSH1718



### DIMENSIONS

L 176/W 157/H 140 cm



### MACHINE WEIGHT

146 kg



### MAX LOADING WEIGHT

400 kg



## STANDING ABDUCTOR

IRSH1719



### DIMENSIONS

L 176/W 113/H 151 cm



### MACHINE WEIGHT

72 kg



### MAX LOADING WEIGHT

200 kg



## UNI/BI- SEATED LEG PRESS

IRSH5001



### DIMENSIONS

L 230/W 212/H 153 cm



### MACHINE WEIGHT

318 kg



### MAX LOADING WEIGHT

450 kg



## SEATED LEG PRESS

IRSH5001B



### DIMENSIONS

L 230/W 212/H 153 cm



### MACHINE WEIGHT

284 kg



### MAX LOADING WEIGHT

450 kg





## UNI-LATERD PRONE LEG CURL

IRSH5004



### DIMENSIONS

L 188/W 197/H 106 cm



### MACHINE WEIGHT

180 kg



### MAX LOADING WEIGHT

250 kg



## PRONE LEG CURL

IRSH5004B



### DIMENSIONS

L 188/W 122/H 107 cm



### MACHINE WEIGHT

114 kg



### MAX LOADING WEIGHT

125 kg



## 45° LEG PRESS

IRFB37B



### DIMENSIONS

L 256/W 148/H 156 cm



### MACHINE WEIGHT

259 kg



### MAX LOADING WEIGHT

400 kg



## UNI-BI-LATERAL LEG PRESS

IRSH6010



### DIMENSIONS

L 266/W 155/H 160 cm



### MACHINE WEIGHT

440 kg



## FULL BODY SQUAT

IRSH5008



### DIMENSIONS

L 261/W 198/H 155 cm



### MACHINE WEIGHT

425 kg



### MAX LOADING WEIGHT

400 kg



## REAR KICK

IRSH1710



### DIMENSIONS

L 134/W 121/H 167 cm



### MACHINE WEIGHT

131 kg



### MAX LOADING WEIGHT

100 kg



## NECK TRAINER

IRSH1715



### DIMENSIONS

L 152/W 149/H 89 cm



### MACHINE WEIGHT

60 kg



### MAX LOADING WEIGHT

60 kg



## HIP THRUST GLUTE MACHINE

IRSH1716



### DIMENSIONS

L 152/W 149/H 89 cm



### MACHINE WEIGHT

90 kg



### MAX LOADING WEIGHT

200 kg





## HIP THRUST

IRSH5010



### DIMENSIONS

L 184/W 155/H 84,5 cm



### MACHINE WEIGHT

205 kg



### MAX LOADING WEIGHT

240 kg



## BELT SQUAT

IRSH1717



### DIMENSIONS

L 196/W 177/H 148 cm



### MACHINE WEIGHT

218 kg



### MAX LOADING WEIGHT

200 kg



## MULTIFUNCTIONAL BACK MUSCLE TRAINER

IRSH1602D



### DIMENSIONS

L 223/W 106/H 155 cm



### MACHINE WEIGHT

215 kg



### MAX LOADING WEIGHT

150 kg



## SLED

IRSH4003A



### DIMENSIONS

L 170/W 99/H 106 cm



### MACHINE WEIGHT

141 kg



## SLED

IRSH4003B



### DIMENSIONS

L 144/W 81/H 97 cm



### MACHINE WEIGHT

72 kg



## LOW DRIVE SLED

IRSH4003C



### DIMENSIONS

L 93/W 80/H 72 cm



### MACHINE WEIGHT

41 kg



## GLUTE BUILDER

IRSH6008



### DIMENSIONS

L 220/W 152/H 52 cm



### MACHINE WEIGHT

125 kg



## SQUAT/ DEADLIFT

IRSH6009



### DIMENSIONS

L 215/W 178/H 82 cm



### MACHINE WEIGHT

147 kg



## MULTI-FUNCTIONAL FREE TRAINING STATION

IRSB2003



### DIMENSIONS

L 199,5/W 157/H 92 cm



### MACHINE WEIGHT

191 kg



## 4 WAY NECK TRAINER

IRSH5005



### DIMENSIONS

L 180/W 134/H 160 cm



### MACHINE WEIGHT

170 kg



### MAX LOADING WEIGHT

60 kg



## BENT-OVER ROW

IRSH5009



### DIMENSIONS

L 162/W 200/H 119 cm



### MACHINE WEIGHT

211 kg



### MAX LOADING WEIGHT

200 kg



## POWER RACK

IRSH1501



### DIMENSIONS

L 180/W 171/H 246 cm



### MACHINE WEIGHT

262 kg





## POWER RACK

IRSH1501B



### DIMENSIONS

L 148/W 144/H 246 cm



### MACHINE WEIGHT

267 kg



## HALF RACK

IRSH1501C



### DIMENSIONS

L 146/W 171/H 241 cm



### MACHINE WEIGHT

193 kg



## POWER RACK

IRSH6006



### DIMENSIONS

L 146/W 171/H 241 cm



### MACHINE WEIGHT

193 kg



## SMITH MACHINE

IRFB24C



### DIMENSIONS

L 222/W 150/H 250 cm



### MACHINE WEIGHT

212 kg



## SMITH MACHINE

IRFB24D



### DIMENSIONS

L 222/W 154/H 250 cm



### MACHINE WEIGHT

241 kg



## 3D SMITH RACK

IRTF1601



### DIMENSIONS

L 249/W 168/H 261 cm



### MACHINE WEIGHT

355 kg



## 3D SMITH HALF RACK

IRTF1601B



### DIMENSIONS

L 220/W 142/H 214 cm



### MACHINE WEIGHT

273 kg



## 3D SMITH MACHINE

IRSH1801



### DIMENSIONS

L 223/W 213/H 249 cm



### MACHINE WEIGHT

300 kg



## MULTIFUNCTIONAL SMITH TRAINER

IRSH5014



### DIMENSIONS

L 202/W 177/H 224 cm



### MACHINE WEIGHT

260 kg







## SELECTORIZED

### **Gateway to progress**

SelectORIZED machines are fitness equipment designed for strength training, featuring a system that allows users to select and adjust the resistance level using a weight stack.

## SEATED LEG CURL

IRFB01



### DIMENSIONS

L 146/W 100/H 157 cm



### MACHINE WEIGHT

220 kg



### WEIGHT STACK

90 kg



## BACK EXTENSION

IRFB02



### DIMENSIONS

L 115/W 106/H 157 cm



### MACHINE WEIGHT

204 kg



### WEIGHT STACK

90 kg



## ABDOMINAL CRUNCH

IRFB03



### DIMENSIONS

L 141/W 107/H 157 cm



### MACHINE WEIGHT

188 kg



### WEIGHT STACK

90 kg



## BICEPS CURL

IRFB04



### DIMENSIONS

L 119/W 106/H 157 cm



### MACHINE WEIGHT

204 kg



### WEIGHT STACK

90 kg



## TRICEPS PRESS

IRFB05



### DIMENSIONS

L 149/W 109/H 157 cm



### MACHINE WEIGHT

210 kg



### WEIGHT STACK

90 kg



## LEG PRESS

IRFB06



### DIMENSIONS

L 191/W 113/H 187 cm



### MACHINE WEIGHT

273 kg



### WEIGHT STACK

90 kg



## SHOULDER PRESS

IRFB07



### DIMENSIONS

L 139/W 140/H 183 cm



### MACHINE WEIGHT

230 kg



### WEIGHT STACK

90 kg



## TRICEPS EXTENSION

IRFB08



### DIMENSIONS

L 119/W 103/H 157 cm



### MACHINE WEIGHT

205 kg



### WEIGHT STACK

90 kg



## CHEST PRESS

IRFB09



### DIMENSIONS

L 129/W 128/H 157 cm



### MACHINE WEIGHT

230 kg



### WEIGHT STACK

90 kg



## SEATED ROW

IRFB10



### DIMENSIONS

L 137/W 118/H 187 cm



### MACHINE WEIGHT

224 kg



### WEIGHT STACK

90 kg



## PECTORAL FLY

IRFB11



### DIMENSIONS

L 142/W 104/H 157 cm



### MACHINE WEIGHT

230 kg



### WEIGHT STACK

90 kg



## LAT PULLDOWN

IRFB12



### DIMENSIONS

L 139/W 137/H 191 cm



### MACHINE WEIGHT

230 kg



### WEIGHT STACK

90 kg





CLARIS

LEG PRESS

## DIP CHIN ASSIST

IRFB13



### DIMENSIONS

L 100/W 145/H 231 cm



### MACHINE WEIGHT

266 kg



### WEIGHT STACK

90 kg



## HIP ABDUCTION ADDUCTION

IRFB14



### DIMENSIONS

L 140/W 115/H 157 cm



### MACHINE WEIGHT

210 kg



### WEIGHT STACK

90 kg



## LEG EXTENSION

IRFB15



### DIMENSIONS

L 121/W 100/H 157 cm



### MACHINE WEIGHT

210 kg



### WEIGHT STACK

90 kg



## LATERAL RAISE

IRFB16



### DIMENSIONS

L 110/W 116/H 157 cm



### MACHINE WEIGHT

292 kg



### WEIGHT STACK

72 kg



## SEATED PULLEY

IRFB17



### DIMENSIONS

L 160/W 89/H 187 cm



### MACHINE WEIGHT

210 kg



### WEIGHT STACK

90 kg



## FLY REAR DELT

IRFB26



### DIMENSIONS

L 140/W 122/H 211 cm



### MACHINE WEIGHT

230 kg



### WEIGHT STACK

90 kg



## PRONE LEG CURL

IRFB28



### DIMENSIONS

L 155/W 105/H 187 cm



### MACHINE WEIGHT

214 kg



### WEIGHT STACK

90 kg



## GLUTE

IRFB29



### DIMENSIONS

L 183/W 97/H 187 cm



### MACHINE WEIGHT

218 kg



### WEIGHT STACK

90 kg



## TORSO ROTATION

IRFB30



### DIMENSIONS

L 113/W 113/H 163 cm



### MACHINE WEIGHT

225 kg



### WEIGHT STACK

90 kg



## NECK FLEXION

IRFB38



### DIMENSIONS

L 158/W 122/H 157 cm



### MACHINE WEIGHT

208 kg



### WEIGHT STACK

90 kg



## STANDING HIP

IRFB41



### DIMENSIONS

L 117/W 107/H 178 cm



### MACHINE WEIGHT

270 kg



### WEIGHT STACK

90 kg





## MULTISTATIONS

### **Unlock the full potential**

Multistation training equipment, delivers both functionality and space-saving convenience. Explore a range designed to optimize your strength training routine without compromising on space, ensuring efficiency of your training.

## POWER RACK

IRSH6001



### DIMENSIONS

L 165/W 180/H 237 cm



### MACHINE WEIGHT

455 kg



### WEIGHT STACK

2 x 90 kg



## POWER RACK

IRSH6001B



### DIMENSIONS

L 165/W 180/H 237 cm



### MACHINE WEIGHT

455 kg



### WEIGHT STACK

2 x 90 kg



## POWER RACK

IRSH6001C



### DIMENSIONS

L 198/W 207/H 237 cm



### MACHINE WEIGHT

547 kg



### WEIGHT STACK

2 x 90 kg



## DUAL ADJUSTABLE PULLEY

IRFB25



### DIMENSIONS

L 109/W 160/H 240 cm



### MACHINE WEIGHT

410 kg



### WEIGHT STACK

2 x 90 kg



## DUAL ADJUSTABLE PULLEY

IRFB35



### DIMENSIONS

L 93/W 155/H 216 cm



### MACHINE WEIGHT

330 kg



### WEIGHT STACK

2 x 90 kg



## CABLE CROSSOVER

IRFB31



### DIMENSIONS

L 329/W 192/H 235 cm



### MACHINE WEIGHT

441 kg



### WEIGHT STACK

2 x 90 kg

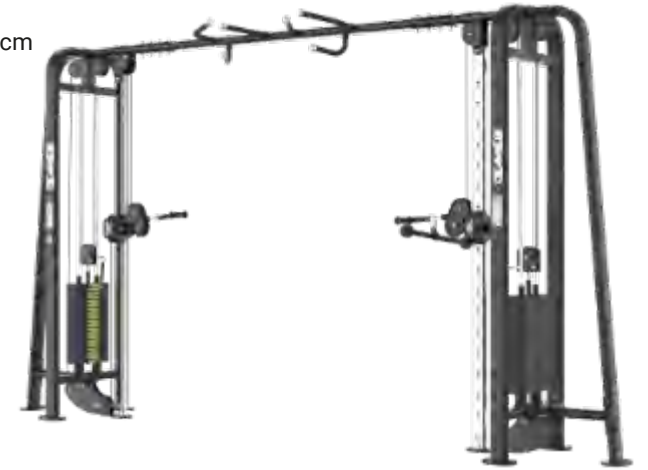

## CABLE CROSSOVER

IRFB31C



### DIMENSIONS

L 329/W 192/H 235 cm



### MACHINE WEIGHT

441 kg



### WEIGHT STACK

2 x 90 kg

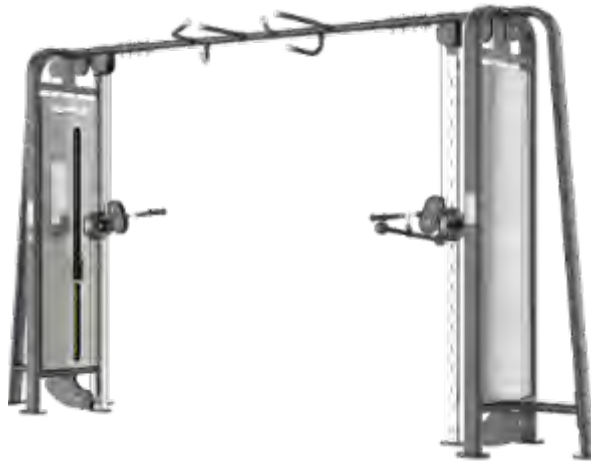

## 4-STATION MULTI GYM

IRFB33



### DIMENSIONS

L 335/W 192/H 235 cm



### MACHINE WEIGHT

630 kg



### WEIGHT STACK

3 x 90 kg, 1 x 54 kg



## 4-STATION MULTI GYM

IRFB33C



### DIMENSIONS

L 335/W 192/H 235 cm



### MACHINE WEIGHT

630 kg



### WEIGHT STACK

3 x 90 kg , 1 x 54 kg



## 5-STATION MULTI GYM

IRFB32



### DIMENSIONS

L 503/W 335/H 235 cm



### MACHINE WEIGHT

804 kg



### WEIGHT STACK

4 x 90 kg , 1 x 54 kg



## 5-STATION MULTI GYM

IRFB32B



### DIMENSIONS

L 503/W 335/H 235 cm



### MACHINE WEIGHT

864 kg



### WEIGHT STACK

4 x 90 kg , 1 x 54 kg



## WALL- MOUNTED CABLE CROSSOVER

IRFB5004B



### DIMENSIONS

L 147/W 51/H 206 cm



### MACHINE WEIGHT

125 kg



### WEIGHT STACK

90 kg



## CABLE CROSSOVER

IRFB127



### DIMENSIONS

L 151/W 200/H 220 cm



### MACHINE WEIGHT

136 kg



### WEIGHT STACK

90 kg



## MULTIGYM

IRHG1701



### DIMENSIONS

L 207/W 128/H 210 cm



### MACHINE WEIGHT

256 kg



### WEIGHT STACK

90 kg



## MULTIGYM

IRHG1701B



### DIMENSIONS

L 217/W 157/H 104 cm



### MACHINE WEIGHT

81 kg



## CABLE CROSSOVER

IRFB527



### DIMENSIONS

L 246/W 359/H 249 cm



### MACHINE WEIGHT

410 kg



### WEIGHT STACK

2 x 90 kg



## 3 STATION MULTIGYM

IRHG1703



### DIMENSIONS

L 229/W 208/H 210 cm



### MACHINE WEIGHT

485 kg



### WEIGHT STACK

2 x 90 kg



## MULTIGYM

IRHG5001



### DIMENSIONS

L 177/W 108/H 209 cm



### MACHINE WEIGHT

200 kg



### WEIGHT STACK

90 kg



## 2 STATION MULTIGYM

IRHG5002



### DIMENSIONS

L 202/W 229/H 209 cm



### MACHINE WEIGHT

255 kg



### WEIGHT STACK

90 kg



## 3 STATION MULTIGYM

IRHG5003



### DIMENSIONS

L 223/W 323/H 209 cm



### MACHINE WEIGHT

310 kg



### WEIGHT STACK

90 kg



## 4 STATION MULTIGYM

IRHG5004



### DIMENSIONS

L 294/W 323/H 209 cm



### MACHINE WEIGHT

470 kg



### WEIGHT STACK

2 x 90 kg



## 5 STATION MULTIGYM

IRHG1505S



### DIMENSIONS

L 423/W 290/H 226



### MACHINE WEIGHT

940 kg



### WEIGHT STACK

5 x 90 kg







## **BENCHES AND RACKS**

### **Impactful training environment**

Benches and racks are essential components of any comprehensive gym setup, providing a versatile foundation for strength training and weightlifting.

## OLYMPIC FLAT BENCH

IRSH1100



### DIMENSIONS

L 165/W 172/H 120 cm



### MACHINE WEIGHT

68 kg



### MAX LOADING WEIGHT

200 kg



## OLYMPIC DECLINE BENCH

IRSH1102



### DIMENSIONS

L 186-201/W 172/H 129



### MACHINE WEIGHT

84 kg



## OLYMPIC INCLINE BENCH

IRSH1104F



### DIMENSIONS

L 191/W 173/H 150 cm



### MACHINE WEIGHT

96 kg



## SHOULDER PRESS

IRSH1106



### DIMENSIONS

L 185/W 166/H 133 cm



### MACHINE WEIGHT

146 kg





## MULTI FUNCTION BENCH

IRSB1502B



### DIMENSIONS

L 138/W 75/H 49-127 cm



### MACHINE WEIGHT

48,5 kg



## MULTI ADJUSTABLE INCLINE BENCH

IRSH1213



### DIMENSIONS

L 150/W 75/H 45-147 cm



### MACHINE WEIGHT

46,2 kg



### MAX LOADING WEIGHT

150 kg



## MULTI FUNCTION BENCH

IRSB5005



### DIMENSIONS

L 133,5/W 67/H 45-110 cm



### MACHINE WEIGHT

70 kg



### MAX LOADING WEIGHT

150 kg



## MULTI FUNCTION BENCH

IRSB5006



### DIMENSIONS

L 142/W 80/H 49-126 cm



### MACHINE WEIGHT

70 kg



### MAX LOADING WEIGHT

150 kg



## FLAT BENCH

IRSH1200



### DIMENSIONS

L 129/W 73/H 43 cm



### MACHINE WEIGHT

27 kg



## UPRIGHT BENCH

IRSH1210



### DIMENSIONS

L 120/W 73/H 111 cm



### MACHINE WEIGHT

29,5 kg



## ADJUSTABLE AB BENCH

IRSH1212



### DIMENSIONS

L 153/W 73/H 86-110 cm



### MACHINE WEIGHT

54,8 kg



## ADJUSTABLE DECLINE AB BENCH

IRSH4002



### DIMENSIONS

L 183/W 76/H 111 cm



### MACHINE WEIGHT

50 kg



## 45° HYPER BACK EXTENSION - ANGLE ADJUSTABLE

IRSH1216F



### DIMENSIONS

L 124/W 102/H 70-79 cm



### MACHINE WEIGHT

52 kg



### MAX LOADING WEIGHT

150 kg



## 45° HYPER BACK EXTENSION

IRSH1216G



### DIMENSIONS

L 124/W 102/H 79-88 cm



### MACHINE WEIGHT

48,8 kg



## SCOTT BENCH

IRSH1220



### DIMENSIONS

L 119/W 89/H 99 cm



### MACHINE WEIGHT

49,3 kg



## SCOTT BENCH

IRYL1220



### DIMENSIONS

L 103/W 83/H 92 cm



### MACHINE WEIGHT

48 kg



## SQUAT RACK

IRSH1300F



### DIMENSIONS

L 167/W 172/H 182 cm



### MACHINE WEIGHT

104 kg



### MAX LOADING WEIGHT

200 kg



## LEG CURL

IRSB5003



### DIMENSIONS

L 186/W 58/H 66 cm



### MACHINE WEIGHT

67 kg



### MAX WEIGHT

150 kg



## PRONE BENCH

IRZX5017



### DIMENSIONS

L 228/W 218/H 120 cm



### MACHINE WEIGHT

158/20 kg



## PRONE PULL UP BENCH

IRSB4001



### DIMENSIONS

L 179/W 70/H 75-100 cm



### MACHINE WEIGHT

103 kg



### MAX LOADING WEIGHT

150 kg





## DRAW MUSCLE MACHINE

IRFB19D



### DIMENSIONS

L 150/W 75/H 117 cm



### MACHINE WEIGHT

50 kg



## ABDOMINAL MACHINE

IRFB18C



### DIMENSIONS

L 157/W 100/H 100 cm



### MACHINE WEIGHT

87 kg



## GLUTE HAM DEVELOPER

IRSH1602



### DIMENSIONS

L 165/W 103/H 118 cm



### MACHINE WEIGHT

110 kg



## GHD (ADJUSTABLE)

IRSH1602C



### DIMENSIONS

L 169/W 120/H 96 cm



### MACHINE WEIGHT

140 kg



## SEATED CALF MACHINE

IRSH750



### DIMENSIONS

L 136/W 75/H 104 cm



### MACHINE WEIGHT

55,3 kg



## INCLINE LEVER ROW

IRSH740



### DIMENSIONS

L 226-240/W 96/H 120 cm



### MACHINE WEIGHT

85 kg



## VERTICAL KNEE RAISE

IRFB20



### DIMENSIONS

L 149/W 140/H 222 cm



### MACHINE WEIGHT

126 kg



## VERTICAL KNEE RAISE

IRFB20D



### DIMENSIONS

L 122/W 74/H 170 cm



### MACHINE WEIGHT

62 kg



## DUMBBELL RACK

IR1304



### DIMENSIONS

L 248/W 74/H 79 cm



### MACHINE WEIGHT

95,5 kg



## DUMBBELL RACK

IRDR1404



### DIMENSIONS

L 248/W 77/H 117 cm



### MACHINE WEIGHT

143 kg



## WEIGHT PLATE TREE

IRSH1011



### DIMENSIONS

L 70/W 68/H 120 cm



### MACHINE WEIGHT

32 kg



## WEIGHT PLATE TREE

IR86031



### DIMENSIONS

L 119/W 68/H 124 cm



### MACHINE WEIGHT

22,5 kg



## OLYMPIC BAR RACK

IR1405



### DIMENSIONS

L 86/W 63/H 33 cm



### MACHINE WEIGHT

16,9 kg



## BARBELL RACK

IR1303



### DIMENSIONS

L 121/W 89/H 148 cm



### MACHINE WEIGHT

87 kg



## KETTLEBELL RACK

IR96041B



### DIMENSIONS

L 141/W 65/H 77 cm



### MACHINE WEIGHT

67 kg



## 10-BALL MDICINE/ SLAM BALL RACK

IR1003L



### DIMENSIONS

L 60/W 36/H 156 cm



### MACHINE WEIGHT

15 kg



**OEAMERBI®**



ITALIAN DESIGN

